



INVITATION FOR FORMAL BIDS

FOR

***2022 CONCRETE STREET SLABS
REMOVAL AND REPLACEMENT***

IN

COTTLEVILLE, MISSOURI

***CITY OF COTTLEVILLE
5490 FIFTH STREET
COTTLEVILLE, MO 63304***

2022 CONCRETE STREET SLAB REPLACEMENT
NOTICE TO CONTRACTORS
Invitation for Formal Bid

Notice is hereby given that the City of Cottleville will receive sealed bids for concrete pavement removal and replacement on various City roads at City Hall, 5490 Fifth Street, Cottleville, Missouri, until *2:00 p.m. on Thursday June 9, 2022*, at which time all bids will be publicly opened and read at City Hall.

The project shall include all work incidental to removal and replacement of concrete street slabs and concrete sidewalk slabs in various subdivisions throughout the City, to be paid for by the square yard. In addition, the project shall include joint and cracksealing of 30 foot wide streets. Method of payment will be per lineal foot for saw cutting, per linear foot of roadway for joint and cracksealing not included in concrete street slab replacement, per square yard for removal and replacement of street slabs, and per square yard for removal and replacement of unsuitable material. Mobilization will be considered incidental to the project; no direct payment will be made. Final payment will be based on quantities measured after the work is complete.

Please draw special attention in the Job Specifications to Concrete Pavement Section 4.6.7.

The successful bidder shall be required to comply with the State Statutory Provisions concerning the payment of prevailing wages on public works, Section 290.210 through 290.340 R.S. MO 1959, as amended 1969 and shall pay to all workmen performing work under this contract not less than the prevailing hourly rate of wages determined by the Department of Labor and Industrial Relation of the State of Missouri. The wage rates applicable to this project have been predetermined as required by law and are set forth in this document.

Missouri Annual Wage Order 28 as amended May 12, 2021 shall be in effect for this project.

The bid proposal shall be made on a form provided by the City, delivered in a sealed envelope, at City Hall on or before the time specified above.

The City reserves the right to require the successful bidder to file proof of his ability to properly execute the project together with his record of successful completion of similar projects. The City reserves the right to reject any and all bids or proposals submitted, or to advertise for new bids. The City reserves the right to defer the acceptance of any proposal and the execution of a contract for a period not exceeding forty five (45) days after the date of opening of the bids. The successful bidder to whom the contract has been awarded shall sign and return the contract and other required certificates and documents in quadruplicate within ten (10) days after the date of the receipt of the award of the contract. The successful bidder shall file certificates with the City that he has obtained and will continue to carry workmen's compensation insurance, public and private liability and property damage insurance and builders risk insurance in the specified amounts for the duration of the contract.

The contractor shall not commence work prior to the date of written notice from the City Engineer and shall complete all work before September 30, 2022. Notice to Proceed is expected to be on or about June 21, 2022

Special Needs: If you have special needs addressed by the Americans with Disability Act, please notify the Assistant City Engineer at (636) 498-6565 ext. 9 at least five (5) working days prior to the bid opening.

The City hereby notifies all bidders that it will affirmatively ensure that in any contract entered into pursuant to this advertisement, businesses owned and controlled by socially and economically disadvantaged individuals will be afforded full opportunity to submit bids in response to this invitation and will not be discriminated against on the grounds of race, color, religion, creed, sex, age, ancestry, or national origin in consideration for an award.

TABLE OF CONTENTS

INFORMATION FOR BIDDERS	IB-1 thru IB-7
PROPOSAL	PROP-1 thru PROP-5
ESTIMATED QUANTITY BREAKDOWN	EQB-1
JOB SPECIFICATIONS	
General Information	JS-1
Safety Program Training Requirement	JS-1 thru JS-2
Employment of Unauthorized Aliens	JS-2 thru JS-5
Construction Requirements	JS-5 thru JS-8
Basis of Payment	JS-8 thru JS-10
Project Submittals and Closeout	JS-10
Type "A" Expansion Joint Drawing	TD-1
Integral Rolled Curb	TD-2
TRAFFIC HANDLING REQUIREMENTS	
Work Zone Traffic Management Plan	WZ-1 thru WZ-2
CONTRACT DOCUMENTS	
Contract Agreement	CA-1 thru CA-7
Performance Bond	PB-1 thru PB-2
Payment and Material Bond	PMB-1
APPENDIX A	
Madison Park Entrance	

INFORMATION FOR BIDDERS FOR
2022 CONCRETE REMOVAL AND REPLACEMENT
IN COTTLEVILLE, MISSOURI

1. RECEIPT AND OPENING OF BIDS:

The City of Cottleville (herein called the "City"), invites bids on the form attached hereto, all blanks of which must be appropriately filled in. Bids will be received at City Hall, 5490 Fifth Street, Cottleville, Missouri, until **2:00 p.m. on June 9, 2022** at which time all bids will be publicly opened and read aloud. The envelopes containing the bids must be sealed, addressed to the Assistant City Engineer, and designated as:

"2022 Bid for Concrete Removal and Replacement."

The City may consider any bid not prepared and submitted in accordance with the provisions hereof and may waive any informalities or reject any or all bids. Any bids may be withdrawn prior to the above scheduled time for the opening of bids or authorized postponement thereof. Any bids received after the time and date specified will be considered as "No Bid" and "Void" and will not be opened.

2. PREPARATION OF BID:

Each bid must be submitted on the prescribed form. All blank spaces for bid prices must be completed, in ink or typewritten. Mistakes must be crossed out, corrections typed or written in ink, and must be initialed by the person signing the bid. An original signature by an authorized officer of the company in ink is required on the submitted bid. All bids will be considered final. No additions, deletions, corrections or adjustments will be accepted after the time of bid opening.

Each bid must be submitted in a sealed envelope bearing on the outside the name of the bidder, his address, the name of the project for which the bid is submitted, and the date and time of bid opening noted in the lower left corner. If forwarded by mail, the envelope containing the bid must be enclosed in another envelope addressed as specified in the bid form.

3. SUBCONTRACTS:

The bidder is specifically advised that any person, firm or other party to whom it is proposed to award a subcontract under this contract must be acceptable to the City. The bidder is also specifically advised that no second-tier subcontracting will be permitted on this project. The successful bidder must provide a list of proposed suppliers and subcontractors which must be accepted prior to commencing work.

4. EXECUTION OF CONTRACT:

The bidder to whom the contract has been awarded shall sign four copies of the contract, performance bond, and payment and material bond and return them to the City within ten (10) days after receipt of the contract.

Failure to execute the contract and bonds and return them to the City within ten (10) days after receipt of

the contract shall be cause for the annulment of the contract award and the forfeiture of the bid security to the City.

The City will not award any bid to an individual or business having any outstanding amounts due from a prior Contract or business relationship with the City or who owes any amount(s) for delinquent taxes, fees or licenses.

5. QUALIFICATIONS OF BIDDER:

The City may make such investigations as it deems necessary to determine the ability of the bidder to perform the work, and the bidder shall furnish to the City, all such information and data for this purpose as the City may request. The City reserves the right to reject any bid if the evidence submitted by, or investigation of, such bidder fails to satisfy the City that such bidder is properly qualified to carry out the obligations of the contract and to complete the work contemplated therein. Conditional bids will not be accepted.

All bidders must possess the necessary and appropriate business and/or professional licenses in their field.

6. BID SECURITY:

Each bid must be accompanied by cash, certified check of the bidder, cashier's check or a bid bond duly executed by the bidder as principal and having as surety thereof a surety company approved by the City, in the amount of 5 percent of the bid. Such cash, check or bid bond will be returned to all except the three lowest bidders within fifteen (15) days after the opening of bids, and the remaining cash, checks, or bid bonds will be returned promptly after the City and the accepted bidder have executed the contract, or, if no award has been made within forty-five (45) days after the date of the opening of bids, upon demand of the bidder at any time thereafter, so long as he has not been notified of the acceptance of his bid.

7. LIQUIDATED DAMAGES:

a. FAILURE TO ENTER INTO CONTRACT:

The successful bidder, upon his failure or refusal to execute and deliver the contract and bonds required within ten (10) days after he has received notice of the acceptance of his bid, shall forfeit to the City as liquidated damages for such failure or refusal, the security deposited with his bid.

b. TIME OF COMPLETION:

Bidder must agree to not commence work prior to the date to be specified in written "Notice to Proceed" from the City and to fully complete the project by September 30, 2022. The City plans to issue the Notice to Proceed on or about June 21, 2022. If the contract work is not fully completed according to the terms of the contract within the time limit specified, the contractor shall pay to the City, as liquidated damages, a sum equal to three hundred (\$300.00) dollars per day for each calendar day until the job is 100% completed, accepted, and approved by the Assistant City Engineer. The job is not considered 100% complete until ALL ITEMS of work, including clearance of deficiencies, are finished.

8. **CONDITIONS OF WORK:**

Each bidder must inform himself fully of the conditions relating to the construction of the project and the employment of labor thereon. Failure to do so will not relieve a successful bidder of his obligation to furnish all material and labor necessary to carry out the provisions of his contract. Insofar as possible, the contractor in carrying out his work must employ such methods or means so as to not cause any interruption of or interference with the work of any other contractor.

9. **ADDENDA AND INTERPRETATIONS:**

No interpretation of the meaning of the plans, specifications or other pre-bid documents will be made to any bidder orally.

Every request for such interpretation should be in writing, addressed to:

City of Cottleville
Attn: Leland Maize
5490 Fifth Street
Cottleville, Missouri 63304

or by e-mail to Leland Maize at leland.maize@cityofcottleville.com

To be given consideration request must be received at least one (1) week prior to the date fixed for the opening of bids.

Any and all such interpretations to the specifications which, if issued, will be faxed, delivered by courier, or mailed by certified mail with return receipt to all prospective bidders (at the respective addresses furnished for such purposes), not later than four (4) days prior to the date fixed for the opening of bids. Failure of any bidder to receive any such addendum or interpretation shall not relieve such bidder from any obligation under his bid as submitted. All addenda so issued shall become part of the contract documents. The contractor shall sign all addenda acknowledgments issued by the City and return it with the bid proposal.

10. **POWER OF ATTORNEY:**

Attorney's-in-fact who sign bid bonds or contract bonds must file with each bond a certified and effectively dated copy of their power of attorney.

11. **LAWS AND REGULATIONS:**

The bidder's attention is directed to the fact that all applicable state laws, municipal ordinances, and the rules and regulations of all authorities having jurisdiction over construction of the project shall apply to the contract throughout, and they will be deemed to be included in the contract the same as though herein written out in full.

12. **METHOD OF AWARD-LOWEST RESPONSIVE, RESPONSIBLE BIDDER:**

The contract will be awarded to the lowest responsive, responsible bidder, however the City reserves the right to reject any or all bids.

13. OBLIGATION OF BIDDER:

At the time of the opening of bids each bidder will be presumed to have inspected the sites and to have read and to be thoroughly familiar with the plans and contract documents (including all addenda). The failure or omission of any bidder to examine any form instrument or document shall in no way relieve any bidder from any obligation in respect to his bid.

14. TAXES:

Bidders shall include in their proposals any sales or use taxes, which they are required by law to pay. The City shall supply the Contractor with a Missouri Project Exemption Certificate. The certificate authorizes the Contractor and any subcontractors to purchase, without sales tax, tangible personal property to be incorporated or consumed in the construction of the project pursuant to Section 144.062 RSMo.

15. RIGHT-OF-WAYS:

The City will provide all right-of-ways upon which work is to be done.

16. INSURANCE:

The contractor, including any sub-contractor(s), shall carry adequate liability, property damage, workers compensation and other such insurance coverages as may be deemed necessary by the City in the performance of the Contract. All insurance(s) shall be written by a company licensed to do business in the State of Missouri and satisfactory to the City in amounts no less than those specified below.

The insurance must include blanket underground coverage including, but not limited to, accident or injury to the destruction of wires, conduit, pipes, mains, sewers, or other similar property, or any apparatus in connection therewith below the surface of the ground, whether or not such injury or accident is caused by and occurs during the use of mechanical equipment, for the purpose of grading of land, paving, backfilling, excavating burrowing, tunneling or drilling. The policy's must provide coverage for accident, injury (or death) to or destruction of any property arising from blasting or explosion or the collapse of or structural damage to any buildings or structures due to grading of land, excavating, burrowing, backfilling or tunneling.

The cost of the insurance shall be included in the price bid for the various items or work and no additional payments will be made therefore.

The City shall have the right to require contractor (and/or sub-contractor) to increase any or all such insurance policy limits while the contract work is in progress in the event the City Engineer, or his designee, determines that unusual or special risks revealed by the work so required and in such amounts as the City may determine to be appropriate.

Certificates of Insurance evidencing such coverage, must be furnished, prior to the signing of the contract with the City. The City shall be named as an Additional Insured on each of the respective policies and include a provision for at least thirty (30) days written notice to the City of any material change or cancellation.

Workers' Compensation: Statutory limits and Employer's Liability with limits no less than \$1,000,000.00.

Automobile, General Liability and Property Damage: Minimum coverage to be maintained by Contractor and each sub-contractor in the amount of \$1,500,000 for bodily injury or death to any one person and \$3,000,000 per occurrence. Property Damage of at least \$1,000,000. In the alternative, a Combined Single Limit policy in the minimum amount of \$3,000,000. Automobile coverage must include non-owned vehicles

17. PERFORMANCE BOND:

A bond will be required for the full amount of the contract price with a surety company authorized to do business in the State of Missouri and satisfactory to the City, conditioned for the faithful performance of this contract and the guarantee of the work. Both contract and bond shall be executed in quadruplicate and in a form acceptable to the City. The cost of the performance bond shall be incidental to the price bid for other items.

18. PAYMENT AND MATERIALS BOND:

A bond will be required for the full amount (100 percent Labor and Material) of the contract price with a surety company authorized to do business in the State of Missouri and satisfactory to the City, conditions for the faithful payment of this Contract. The bond shall be executed in quadruplicate and in a form acceptable to the City. The cost of the payment and materials bond shall be incidental to the price bid for other items.

19. BID RESULTS:

The final bid results will be made public after the completion of the bidding process.

20. USE OF COTTLEVILLE IN ADVERTISING:

The successful bidder is specifically denied the right of using in any form or medium the names of Cottleville for public advertising unless express written permission is granted.

21. AMERICAN MADE:

In accordance with the Domestic Product Procurement Act (hereinafter referred to as the Buy American Act) RSMo 34.350-34.359, the bidder is advised that any goods purchased or leased by any public agency where the purchase, lease or contract involves the expenditure of twenty-five thousand dollars (\$25,000) or more, shall be manufactured or produced in the United States. Section 34.350.2(1) of that Act specifies that the term "public agency" includes all political subdivisions of the State of Missouri, which definition includes counties.

The requirements of the Buy American Act shall not apply if other exceptions to the Buy American mandate in RSMo 34.353 are met. If the bidder claims there is only one line of the good manufactured or produced in the United States, RSMo 34.353 (2), or that one of the exceptions of RSMo 34.353 (3) applies, the Department Head or Elected Official bears the burden of certification as required prior to the award of a contract.

In accordance with the Buy American Act, the bidder must provide proof of compliance with RSMo 34.353. Therefore the bidder should complete and return Exhibit A, certification regarding proof of compliance, with the bid. This document must be satisfactorily completed prior to an award of a contract.

22. GOVERNING STANDARD SPECIFICATIONS AND DEFINITION CHANGES

The general requirements, provisions and technical specifications governing the completion of the work contemplated shall be the **St. Charles County Standard Specifications for Arterial Highway Construction, 2006** (hereinafter referred to as the Standard Specifications) for the roadway and insurance requirements together with the General and Job Special Provisions and other City and State requirements contained in the contract documents.

Special attention is called to the following sections:

- A. The contractor shall comply with all the provisions of Section 806 in regards Temporary Water Pollution and the Storm Water Pollution Prevention Plan.
- B. The contractor shall comply Section 106.9 in regards to the Buy America Policy.
- C. The contractor shall be familiar with Sections 104.2 Differing Site Conditions, 104.3 Changes in the Work, 104.4 Notification of Differing Site Conditions and Changes in the Work, 105.1.2 Suspension of Work, 108.6 Temporary Suspension of Work, 108.15 Suspension of Work Directed by the Engineer, 109.4 Differing Site Conditions and Changes in the Work, and 109.12 Change Orders.

23. SCOPE CHANGES

The City reserves the right to remove a portion of the work if insufficient funds are available to cover the entire amount of the bid.

24. SAFETY PROGRAM TRAINING REQUIREMENT:

All contractors and subcontractors are subject to and must comply with the requirements of section 292.675 of the Revised Statutes of Missouri, which are included in the Job Specifications.

25. EMPLOYMENT OF UNAUTHORIZED ALIENS PROHIBITED (Missouri Revised Statutes Section 285.530)

As a condition for the award of any contract or grant in excess of five thousand dollars by Cottleville to a business entity, the business entity shall, by sworn affidavit and provision of documentation**, affirm its enrollment and participation in a federal work authorization program (**E-Verify**) with respect to the employees working in connection with the contracted services. Every such business entity shall sign an affidavit affirming that it does not knowingly employ any person who is an unauthorized alien in connection with the contracted services. [RSMO Sec. 285.530 (2)]

An employer may enroll and participate in a federal work authorization program (**E-Verify**) and shall verify the employment eligibility of every employee in the employer's hire whose employment commences after the employer enrolls in a federal work authorization program. The employer shall retain a copy of the dated verification report received from the federal government. Any business entity that participates in such program shall have an affirmative defense that such business entity has not violated subsection 1 of RSMO Sec. 285.530. [RSMO Sec. 285.530 (4)]

Any entity contracting with Cottleville shall only be required to provide the referenced affidavit on an annual basis. A copy of the affidavit is included in this bid request. Vendors may choose to send the required documentation using one of the following options:

- Send the notarized affidavit and E-Verify MOU signature page to: City of Cottleville, Attn: Leland Maize, 5490 Fifth Street, Cottleville, MO 63304 prior to responding to any solicitations; **OR**
- Send the notarized affidavit and E-Verify MOU signature page along with a bid solicitation response.

These documents will be kept on file. The notarized affidavit and E-Verify MOU signature page will remain current for **one year** from the date of the notarized affidavit.

**** PLEASE NOTE:**

Acceptable enrollment and participation documentation consists of a valid copy of the signature page (page 11) of the E-Verify Memorandum of Understanding, completed and signed by the Contractor, and the Department of Homeland Security - Verification Division

The online address to enroll in the E-verify program is:

https://e-verify.uscis.gov/enroll/StartPage.aspx?JS=YES

26. OPEN RECORDS

Any and all information contained in or submitted with the bid becomes a public record subject to the Missouri Sunshine Law when the bids are opened. If the bidder believes that any information contained in or submitted with the bid is protected from disclosure by the Missouri Sunshine Law, the bidder must clearly identify what information the bidder believes is so protected and must also clearly identify the legal basis therefor.

BID PROPOSAL

In response to the advertisement inviting proposals for the removal and replacement of concrete streets and in accordance with the specifications and information contained herein, the undersigned proposes to construct the specified work at the following prices (suitable bid security is attached):

ITEM NO.	DESCRIPTION	QUANTITY	UNIT PRICE	COST
1	Mobilization - incidental with the cost of the contract. No payment will be made.	XXXXXX XXXXXX	XXXXXXX XXXXXXX	XXXXXXX XXXXXXX
2	Saw Cutting	4058 LF		
3	Concrete Replacement, 6-inch thick with EMPC concrete mix	3371 SY		
4	Concrete Replacement, 4-inch thick with EMPC concrete mix - Sidewalk	23 SY		
5	Seal 30' Wide Concrete Streets	2808 LF		
6	Unsuitable Subgrade	0 SY		

TOTAL _____

STREET REPAIR LOCATIONS

All of the following locations have been marked in the field.

Madison Park		
<u>Street Location</u>	<u>Quantity (SY)</u>	<u>Sawcut (LF)</u>
Entrance (See Exhibit A)	1306	72
Entrance (See Exhibit A)	3	34
224-226 Madison Park Dr.	1	19
224-226 Madison Park Dr.	81	72
224 Madison Park Dr.	6	52
222 Madison Park Dr.	6	52
222 Madison Park Dr.	6	52
222 Madison Park Dr.	24	34
220 Madison Park Dr.	170	63
220 Madison Park Dr.	3	43
218 Madison Park Dr.	35	81
217 Madison Park Dr.	10	25
214-216 Madison Park Dr.	79	105
214 Madison Park Dr.	3	28
212 Madison Park Dr.	6	54
212 Madison Park Dr.	6	54
210 Madison Park Dr.	6	52
210 Madison Park Dr.	2	18
301 Lake Side View Ln.	55	87
301 Lake Side View Ln.	92	26
305 Lakeside View Ln	3	30
305 Lakeside View Ln	3	28
305 Lakeside View Ln	4	29
315 Lakeside View Ln	11	26
317 Lakeside View Ln	41	72
321 Lakeside View Ln	3	30
323 Lakeside View Ln	10	41
325 Lakeside View Ln	3	34
329 Lakeside View Ln	3	19
329 Lakeside View Ln	1	12
329 Lakeside View Ln	16	45
331 Lakeside View Ln	15	44
356 Lakeside View Ln	11	42
353 Lakeside View Ln	38	82

351 Lakeside View Ln	6	110
351 Lakeside View Ln	19	
351 Lakeside View Ln	4	
351 Lakeside View Ln	208	
348 Lakeside View Ln	14	48
346 Lakeside View Ln	44	131
346 Lakeside View Ln Cl+	23	
346 Lakeside View Ln Cl+	5	
346 Lakeside View Ln Cl+	12	
Lakeside View & Scenic Pass	3	31
Lakeside View & Scenic Pass	22	26
Lakeside View & Scenic Pass	27	38
Lakeside View & Scenic Pass	29	7
Lakeside View & Scenic Pass	39	36
Lakeside View & Scenic Pass	16	19
343Lakeside View Ln	98	
343Lakeside View Ln	76	
339 Lakeside View Ln	29	49
337 Lakeside View Ln	66	128
337 Lakeside View Ln	16	
147 Scenic Pass	17	65
147 Scenic Pass	6	
145 Scenic Pass	13	50
142 Scenic Pass	25	48
141-143 Scenic Pass	57	80
140-142 Scenic Pass	35	47
138 Scenic Pass	6	56
135 Scenic Pass	1	16
128-130 Scenic Pass	26	47
126-128 Scenic Pass	12	60
126-128 Scenic Pass	1	14
127 Scenic Pass	10	48
127 Scenic Pass	7	
122 Scenic Pass	6	52
120 Scenic Pass	4	40
118 Scenic Pass	3	30
116 Scenic Pass	2	24
114 Scenic Pass	2	24
114 Scenic Pass	6	52

112 Scenic Pass	6	52
112 Scenic Pass	6	52
110 Scenic Pass	4	36
110 Scenic Pass	1	14
108 Scenic Pass	20	52
Scenic Pass & Lakeview	25	50
Scenic Pass & Lakeview	1	
Lakeside View West	1	14
Lakeside View West	6	52
4 Curb Inlet Sumps	16	
TOTAL	3141	3254
<u>Sidewalk Location</u>	<u>Quantity (SY)</u>	<u>Sawcut (LF)</u>
201 Madison Park Dr. Sidewalk	4	8
325 Lakeside View Ln Sidewalk	2	8
126 Scenic Pass Sidewalk	2	8
126 Scenic Pass Sidewalk	2	
207 Madison Pk Dr Sidewalk	2	8
207 Madison Pk Dr Sidewalk	2	
219 Madison Pk Dr Sidewalk	2	8
219 Madison Pk Dr Sidewalk	2	
TOTAL	18	40
Rosedale		
Street Location	Quantity (SY)	Sawcut (LF)
Entrance	2	20
Entrance	30	56
2063 Roselake Circle	13	33
2074 Roselake Circle	7	34
2074 Roselake Circle	20	54
2074 Roselake Circle	1	12
2155 Roselake Circle	5	8
2155 Roselake Circle	1	
2155 Roselake Circle	7	24
2146 Roselake Circle	2	16
2146 Roselake Circle	14	39
2146 Roselake Circle	2	16
2138 Roselake Circle	8	34
2138 Roselake Circle	1	13
2134 Roselake Circle	20	53

2134 Roselake Circle	12	24
2118 Roselake Circle	14	48
1 Silkrose Ct.	17	52
1 Silkrose Ct.	2	30
1 Silkrose Ct.	2	
1 Silkrose Ct.	6	44
2110 Roselake Circle	9	40
2106 Roselake Circle	13	44
2108 Roselake Circle	20	54
2090 Roselake Circle	2	8
TOTAL	230	756
<u>Sidewalk Location</u>	<u>Quantity (SY)</u>	<u>Sawcut (LF)</u>
2130 Roselake Circle Sidewalk	5	8
TOTAL	5	8
GRAND TOTAL (STREET)	3371 SY	4010 LF
GRAND TOTAL (SIDEWALK)	23 SY	48 LF

JOINT AND CRACKSEALING LOCATIONS

Street	Subdivision	Centerline Length
Roselake Circle	Rosedale	2521 LF
Silkrose Court	Rosedale	208 LF
Blossom Bay Court	Rosedale	79 LF
	GRAND TOTAL	2808 LF

The undersigned has examined the specifications for the project and has satisfied himself as to the work to be done and conditions under which it must be carried out.

This proposal shall be equally binding to all heirs, administrators, executors, successors, and assigns.

FIRM NAME _____

BY _____

TITLE _____

ADDRESS _____

TELEPHONE _____

DATE _____

THIS FORM MUST BE COMPLETED AND ENCLOSED WITH THE BID

Audit Clause for Contracts

Examination of Records

The Contractor's records which shall include, but not be limited to, accounting records (hard copy, as well as computer readable data), written policies and procedures, subcontractor files, indirect cost records, overhead allocation records, correspondence, instructions, drawings, receipts, vouchers, memoranda, and any other data relating to this contract shall be open to inspection and subject to audit and/or reproduction by the City Auditor, or a duly authorized representative from the City, at the City's expense. The contractor shall preserve all such records for a period of three years, unless permission to destroy them is granted by the City, or for such longer period as may be required by law, after the final payment. Since the Contractor is not subject to the Missouri Sunshine Law (Chapter 610, RSMo), information regarding the Contractor's operations obtained during audits will be kept confidential.

The Contractor shall require all subcontractors under this contract to comply with the provisions of this article by including the requirements listed above in written contracts with the subcontractors.

Vendor Information

Company Name: _____

Business Address: _____

Business Hours _____

Phone: _____ FAX: _____

Email address: _____

Contact Person: _____

Authorized Signature: _____
(Indicates acceptance of all bid terms and conditions)

Date: _____

ANTI-COLLUSION STATEMENT

STATE OF MISSOURI

CITY/CITY OF _____

_____ being first duly sworn, deposes and says that he is

_____ Title of Person Signing

of _____

_____ Name of Bidder

that all statements made and facts set out in the proposal for the above project are true and correct; and the bidder (The person, firm, association, or corporation making said bid) has not, either directly or indirectly, entered into any agreement, participated in any collusion, or otherwise taken any action in restraint of free competitive bidding in connection with said bid or any contract which may result from its acceptance.

Affiant further certifies that bidder is not financially interested in, or financially affiliated with, any other bidder for the above project.

BY _____

BY _____

BY _____

SWORN to before me this _____ day of _____ 20 ____.

Notary Public

My Commission Expires _____

AFFIDAVIT OF WORK AUTHORIZATION

The bidder/contractor who meets the section 285.525, RSMo definition of a business entity must complete and return the following Affidavit of Work Authorization.

Comes now _____ (Name of Business Entity Authorized Representative) as _____ (Position/Title) first being duly sworn on my oath, affirm _____

Business Entity Name) is enrolled and will continue to participate in the E-Verify federal work authorization program with respect to employees hired after enrollment in the program who are proposed to work in connection with the services related to contract(s) with the City for the duration of the contract(s), if awarded in accordance with subsection 2 of section 285.530, RSMo. I also affirm that _____

_____ (**Business Entity Name**) does not and will not knowingly employ a person who is an unauthorized alien in connection with the contracted services provided to the contract(s) for the duration of the contract(s), if awarded.

In Affirmation thereof, the facts stated above are true and correct. (The undersigned understands that false statements made in this filing are subject to the penalties provided under section 575.040, RSMo.)

Authorized Representative's Signature

Printed Name

Title

Date

E-Mail Address

Subscribed and sworn to before me this _____ of _____. I am
(DAY) (MONTH, YEAR)

commissioned as a notary public within the City of _____, State of
(NAME OF CITY)

_____, and my commission expires on _____.
(NAME OF STATE) (DATE)

Signature of Notary

Date

EXHIBIT A

**CITY of COTTLEVILLE
DOMESTIC PRODUCTS PROCUREMENT ACT (BUY AMERICAN)**

The Missouri Domestic Products Procurement Act (34.350-34.359 RSMo) requires that for all bids with a value of \$25,000 or more, the goods or commodities purchased by any public agency (which definition includes all political subdivisions of the State, including counties) or used or supplied in the construction, alteration, repair, or maintenance of any public works must be **manufactured or produced** in the United States. As defined in 34.350 RSMo, United States means the United States of America, the District of Columbia, and all territories and possessions subject to the jurisdiction of the United States. The law also requires that the bidder must provide proof of compliance. **Note: In general, if an import tariff is applied to an item, it does not qualify for the Buy American preference. In addition, Most Favored Nation status does not allow application of the preference.**

Section A – All Products Are Manufactured or Produced In U.S.

If all products bid qualify as domestic products under Missouri law, complete only Section A.

I hereby certify that all products qualify as domestic, that the information provided is true and correct, and complies with all provisions of Sections 34.350-34.359 RSMo. I understand that any misrepresentation herein constitutes the commission of a class A misdemeanor pursuant to Section 34.355 of the Revised Statutes of Missouri.
SIGNATURE
COMPANY NAME

If Section A is completed, do not complete Section B.

Section B – Only One Product Line or No Products Are Manufactured or Produced In U.S.

If only one product line or no products are manufactured or produced in the U.S. complete only section B.

I hereby certify that there is only one product line or no product manufactured or produced in the U.S., that the information provided is true and correct, and complies with all provisions of Sections 34.350-34.359 RSMo. I understand that any misrepresentation herein constitutes the commission of a class A misdemeanor pursuant to Section 34.355 of the Revised Statutes of Missouri.
SIGNATURE
COMPANY NAME

Section C – Products May Qualify Because of Qualifying Treaty

If some or all products bid qualify for domestic status because of a trade treaty, etc., then the bidder must identify each product, country and qualifying treaty, etc. below. The bidder must list ALL products which are or may qualify as domestic below. If more space is needed, please copy this form and submit as an attachment.

BID ITEM NUMBER(S)	COUNTRY WHERE MANUFACTURED OR PRODUCED	QUALIFYING TREATY, LAW, AGREEMENT, OR REGULATION

SECTION C

I hereby certify that the specific items listed above are domestic, that the information provided is true and correct, and complies with all provisions of Sections 34.350-34.359 RSMo. I understand that any misrepresentation herein constitutes the commission of a class A misdemeanor pursuant to Section 34.355 of the Revised Statutes of Missouri.
SIGNATURE
COMPANY NAME

CERTIFICATION OF NON-SEGREGATION

By submission of this bid I certify that I do not maintain or provide for my employees any segregated facilities at any of my establishments, and that I do not permit my employees to perform their services at any location, under my control, where segregated facilities are maintained. I certify further that I will not maintain or provide for my employees any segregated facilities at any of my establishments, and that I will not permit my employees to perform their services at any locations, under my control, where segregated facilities are maintained. I agree that a breach of this certification is a violation of the Equal Opportunity clause in this contract. As used in this certification, the term "segregated facilities" means any waiting rooms, work areas, rest rooms and wash rooms, restaurants and other eating areas, time clocks, locker rooms and other storage or dressing areas, parking lots, drinking fountains, recreation or entertainment areas, transportation and housing facilities provided for employees which are segregated by explicit directive or are in fact segregated on the basis of race, color, religion or national origin because of habit, local custom or otherwise. I further agree that I will obtain identical certifications from proposed subcontractors prior to the award of subcontracts exceeding \$10,000 which are not exempt from the provisions of the Equal Opportunity clause; that I will retain such certifications in my files, and that I will forward this notice to such proposed Contractors.

SIGNED:

Contractor: _____

By: _____

Date: _____

JOB SPECIFICATIONS

1. GENERAL INFORMATION

The City of Cottleville, Missouri, is receiving sealed proposals for concrete street removal and replacement with existing depth concrete (6-inch minimum), subgrade removal and replacement with compacted base rock 4-inch thick, and backfill with topsoil, seed and straw.

All work and material shall be in accordance with the St. Charles County Standard Specifications for Arterial Highway Construction – 2020, unless modified herein, and shall be subject to approval by the Cottleville City Engineer.

The contractor shall comply with the State Statutory Provisions concerning the payment of prevailing wages on public works Section 290.210 through 290.340 RSMo 1959 as amended 1969, and shall pay to all workmen performing work under this contract not less than the prevailing hourly rate of wages determined by the Department of Labor and Industrial Relations of the State of Missouri. The contractor shall forfeit to the City, one hundred (\$100.00) dollars for each calendar day, or portion thereof, such workman is paid less than the said stipulated rates for any work done under said contract by him or by any subcontract under him.

Special attention is directed to Paragraph 107.4.1 of the Standard Specifications regarding the identification of the Contractor's Safety Officer. In cases of calls from the City Police Department or other public safety agencies regarding public safety hazards arising from or related to the work performed under this contract, the City will first try to contact the Contractor's on-site representatives (Superintendent or Project Manager) for correction. When unable to reach the on-site representatives, or in cases where they are non-responsive, the City will contact the Safety Officer. It will be the responsibility of the Superintendent, Project Manager, or Safety Officer to take the actions necessary to immediately correct the public safety concerns identified, regardless of the day or time.

Special attention is also directed to Paragraph 612.30.2 Flaggers and the requirements therein. Additional flaggers may be required where side streets intersect between the two end of work zone flaggers. It is the Contractor's responsibility to provide sufficient flaggers to handle the traffic efficiently and safely.

The Applicant for this Contract will be required to provide proof of lawful presence in accordance with the requirements of Section 208.009 RSMo at or before the Pre-construction Conference. The Applicant for a Corporation or Company will be considered to be the person signing either the Bid Documents and/or the Contract. Proof of lawful presence can be a Missouri Driver's License or any other documentation listed in the statute.

2. CONSTRUCTION SAFETY PROGRAM REQUIRED:

All contractors and subcontractors are subject to and must comply with the requirements of section 292.675 of the Revised Statutes of Missouri, which is included below:

RSMo Section 292.675

The Illegal Aliens and Immigration Status Verification Bill

292.675. Definitions--on-site training required--workers to maintain documentation of completion of training--resolution or ordinance required--violations, penalty--rulemaking authority

1. As used in this section, the following terms shall mean:

(1) "Construction", construction, reconstruction, demolition, painting and decorating, or major repair;

(2) "Contractor", any person entering into a contract with a public body for construction of public works which employs "on-site employees" for purposes of completion of the contract;

(3) "Department", the department of labor and industrial relations;

(4) "On-site employee", laborers, workmen, drivers, equipment operators, and craftsmen employed by contractors and subcontractors to be directly engaged in construction at the site of the public works. "Directly engaged in construction" shall mean work performed in the actual erection of the structure or completion of the improvement constituting the public works. In addition, employees working at a nearby or adjacent facility used by the contractor or subcontractor for construction of the public works shall be deemed "on-site employees". Persons engaged solely in the transportation of materials, fuel, or equipment to the site of the public works shall not be deemed to be "directly engaged in construction;

(5) "Person", any natural person, joint venture, partnership, corporation, or other business or legal entity;

(6) "Public body", the State of Missouri or any officer, official, authority, board or commission of the state, or other political subdivision thereof, or any institution supported in whole or in part by public funds;

(7) "Public works", all fixed works constructed for public use or benefit or paid for wholly or in part out of public funds. "Public works" includes any work done directly by any public utility company when performed by it pursuant to the order of the public service commission or other public authority whether or not it be done under public supervision or direction or paid for wholly or in part out of public funds when let to contract by said utility;

(8) "Subcontractor", any person entering into a subcontract with a contractor for construction of public works which employs "on-site employees" for purposes of completion of the contract.

2. Any contractor for any public body for purposes of construction of public works and any

subcontractor to such contractor shall provide a ten-hour Occupational Safety and Health Administration (OSHA) construction safety program for their on-site employees which includes a course in construction safety and health approved by OSHA or a similar program approved by the department which is at least as stringent as an approved OSHA program, unless such employees have previously completed the required program. All employees who have not previously completed the program are required to complete the program within sixty days of beginning work on such construction project.

3. Any employee found on a work site subject to this section without documentation of the successful completion of the course required under subsection 2 of this section shall be afforded twenty days to produce such documentation before being subject to removal from the project.

4. The public body shall specify the requirements of this section in the resolution or ordinance and in the call for bids for the contract. The contractor to whom the contract is awarded and any subcontractor under such contractor shall require all on-site employees to complete the ten-hour training program required under subsection 2 of this section or such employees must hold documentation of prior completion of the program. The public body awarding the contract shall include this requirement in the contract. The contractor shall forfeit as a penalty to the public body on whose behalf the contract is made or awarded, two thousand five hundred dollars plus one hundred dollars for each employee employed by the contractor or subcontractor, for each calendar day, or portion thereof, such employee is employed without the required training. The penalty shall not begin to accrue until the time period in subsections 2 and 3 of this section have elapsed. The public body awarding the contract shall include notice of these penalties in the contract. The public body awarding the contract shall withhold and retain therefrom all sums and amounts due and owing as a result of any violation of this section when making payments to the contractor under the contract. The contractor may withhold from any subcontractor sufficient sums to cover any penalties the public body has withheld from the contractor resulting from the subcontractor's failure to comply with the terms of this section. If the payment has been made to the subcontractor without withholding, the contractor may recover the amount of the penalty resulting from the fault of the subcontractor in an action maintained in the circuit court in the City in which the public works project is located from the subcontractor.

5. In determining whether a violation of this section has occurred, and whether the penalty under subsection 4 of this section shall be imposed, the department shall investigate any claim of violation. Upon completing such investigation, the department shall notify the public body and any party found to be in violation of this section of its findings and whether a penalty shall be assessed. Determinations under this section may be appealed in the circuit court in the City in which the public

works project is located.

6. If the contractor or subcontractor fails to pay the penalty within forty-five days following notification by the department, the department shall pursue an enforcement action to enforce the monetary penalty provisions of subsection 4 of this section against the contractor or subcontractor found to be in violation of this section. If the court orders payment of the penalties as prescribed under subsection 4 of this section, the department shall be entitled to recover its actual cost of enforcement in addition to such penalty amount.

7. The department may establish rules and regulations for the purpose of implementing the provisions of this section. Any rule or portion of a rule, as that term is defined in section 536.010, RSMo, that is created under the authority delegated in this section shall become effective only if it complies with and is subject to all of the provisions of chapter 536, RSMo, and, if applicable, section 536.028, RSMo. This section and chapter 536, RSMo, are nonseverable and if any of the powers vested with the general assembly pursuant to chapter 536, RSMo, to review, to delay the effective date, or to disapprove and annul a rule are subsequently held unconstitutional, then the grant of rulemaking authority and any rule proposed or adopted after August 28, 2008, shall be invalid and void.

8. This section shall not apply to work performed by public utilities which are under the jurisdiction of the public service commission, or their contractors, or work performed at or on facilities owned or operated by said public utilities.

9. The provisions of this section shall not apply to rail grade crossing improvement projects where there exists a signed agreement between the railroad and the Missouri department of transportation or an order issued by the department of transportation ordering such construction.

10. This section shall take effect on August 28, 2009.

(Statutes are subject to change by the Missouri General Assembly.)

3. EMPLOYMENT OF UNAUTHORIZED ALIENS PROHIBITED (*Missouri Revised Statutes Section 285.530*)

As a condition for the award of any contract or grant in excess of five thousand dollars by Cottleville to a business entity, the business entity shall, by sworn affidavit and provision of documentation**, affirm its enrollment and participation in a federal work authorization program (**E-Verify**) with respect to the employees working in connection with the contracted services. Every such business entity shall sign an affidavit affirming that it does not knowingly employ any person who is an unauthorized alien in connection with the contracted services. [RSMO Sec. 285.530 (2)]

An employer may enroll and participate in a federal work authorization program (**E-Verify**) and shall verify the employment eligibility of every employee in the employer's hire whose employment commences after the employer enrolls in a federal work authorization program.

CONCRETE REMOVAL AND REPLACEMENT

The employer shall retain a copy of the dated verification report received from the federal government. Any business entity that participates in such program shall have an affirmative defense that such business entity has not violated subsection 1 of RSMO Sec. 285.530. [RSMO Sec. 285.530 (4)]

Any entity contracting with the City of Cottleville shall only be required to provide the referenced affidavit on an annual basis. A copy of the affidavit is included in this bid request. Vendors may choose to send the required documentation using one of the following options:

- Send the notarized affidavit and E-Verify MOU signature page to: City of Cottleville, Attn: Rich Francis, 5490 Fifth Street, Cottleville, MO 63304 prior to responding to any solicitations; **OR**
- Send the notarized affidavit and E-Verify MOU signature page along with a bid solicitation response.

These documents will be kept on file. The notarized affidavit and E-Verify MOU signature page will remain current for **one year** from the date of the notarized affidavit.

**** PLEASE NOTE:**

Acceptable enrollment and participation documentation consists of a valid copy of the signature page (page 11) of the E-Verify Memorandum of Understanding, completed and signed by the Contractor, and the Department of Homeland Security - Verification Division

The online address to enroll in the E-verify program is:

<https://e-verify.uscis.gov/enroll/StartPage.aspx?JS=YES>

4. CONSTRUCTION REQUIREMENTS

4.1 General

4.1.1 Where conflicts may exist between the Job Specifications and the Standard Specifications, the Job Specifications will be applicable.

4.1.2 Deleted

4.2 Material Tickets. Concrete and Rock tickets must be supplied for all material supplied to the project.

4.3 Full Depth Saw Cutting. Full depth saw cutting shall be required at the limits of the pavement removal, both longitudinal and transverse. Extreme care shall be taken to avoid damage to adjacent concrete pavement to remain in place. Damage to adjacent pavements will result in additional removals and replacements at the Contractor's expense. Saw cutting shall be paid at the contract unit price in the bid.

4.4 Subgrade. All subgrade must be uniform and compacted to St. Charles County Specifications.

4.5 Base rock. All base rock must be compacted to St. Charles County Specifications. Use of minimum 5-ton smooth drum vibratory roller required. Use of vibrating tamping plate in areas inaccessible to 5-ton minimum vibratory may be permitted.

4.6 Concrete Pavement

CONCRETE REMOVAL AND REPLACEMENT

4.6.1 The pavement shall not be opened to traffic until the concrete has attained a minimum compressive strength of 4000 psi.

4.6.2 A vibratory strike-off float is required.

4.6.3 A 10-foot straight edge is required in accordance with the specifications.

4.6.4 White pigmented membrane curing compound shall be applied under pressure to the concrete at a minimum rate of 150 square feet per gallon or as otherwise required to completely cover the concrete surface. Special attention is directed to paragraph 502.12 of the standard specifications. Apply cure compound immediately after finishing operations have been completed, and marring of the concrete will not occur.

4.6.5 Newly placed concrete pavement must be monitored to deter any vandalism until the concrete has cured sufficiently. If vandalism occurs and it is determined that the pavement needs to be replaced, replacement will be at the contractor's expense in those cases where the necessary monitoring was not done.

4.6.6 Repair of damage to any driveway or curb shall be made at the contractor's expense.

4.6.7 Drilling and doweling into existing concrete pavement shall be done with deformed epoxy coated steel bars, ASTM A615, Grade 40 or 60, minimum 16 inches long, 3/4 inch diameter. Dowel bars shall be placed on thirty (30) inch centers for longitudinal joints and eighteen (18) inch centers on transverse joints. **A hole 1/8 inch larger than the dowel shall be drilled into the center of the existing pavement so the dowel can be inserted in half the length of the dowel. The dowel must be epoxied in place. Epoxy shall be Liquid Roc 300 or approved equal. Contractor shall follow all manufacturer's specifications for product use, including but not limited to cleaning dust from the drilled hole using a nylon brush; use of pressurized air to blow dust from hole; filling the drilled hole starting at the back to reduce air pockets; inserting bars by hand in a twisting motion to prevent "popping" of epoxy from drilled holes (use of a hammer will not be permitted).** The drilling, epoxy, and dowelling is incidental to the placement of the concrete and will not be paid for separately.

4.6.8 Joint repairs will be from 4-foot to under 8-foot in width (2-foot to 4-foot on each side of the defective joint) as marked in the field. All requirements for slab replacement will also be required for joint repairs. All repairs 8 feet and over in width will be paid for as slab replacement.

4.6.9 *Deleted*

4.6.10 At back of curb to concrete driveway, a 6" x 1" expansion joint shall be installed. At back of curb to concrete sidewalk or ramp area, a 6" x 1/2" expansion joint shall be installed. Expansion joint material is considered incidental and will not be paid for separately. If required by City representative, Ceramar expansion joint material used at driveways will be paid for at unit price. Ceramar material used at driveways also requires 16 penny nails every 12" to anchor Ceramar to concrete and prevent float out.

4.7 Pavement Joints

4.7.1 All joints shall be saw cut to one third of the pavement depth and be 3/8 inch in width. Routed or

grooved joints will NOT be accepted. This saw cutting is incidental to the placement of the concrete and will not be paid for separately.

4.7.2 All joints shall be sealed with either ASTM D6690 Type I or II rubberized material. This includes joints between back of curb and driveways, sidewalks, or other hard surfaces. Joints where a newly placed slab abuts an existing slab, the joint shall be saw cut 3/8 inch wide and 3/4 inch in depth to provide a reservoir to accept the new sealer. Joints on street surface must be squeegeed immediately after sealing to seal off the joint and provide a smooth riding surface. Joints at back of curb to driveway and back of curb to sidewalk shall not be squeegeed.

4.7.3 An expansion strip may be necessary to be installed where there is an existing slab with a crack that could cause the crack to spread into the newly placed concrete pavement. Installation of expansion strip is incidental to the placement of the concrete and will not be paid for separately.

4.7.4 Type "A" modified expansion joints will be installed by the contractor (details enclosed – TD-1) at locations determined by the City. The Contractor will supply the ceramar expansion material. All Type "A" modified expansion joints shall be sealed 30 days after replacement. Type "A" modified expansion joints that are installed when concrete is poured require 16 penny nails every 12" to anchor ceramar to concrete and prevent float out. Type "A" modified expansion joints that are saw-cut and installed later shall be 1 3/4" to 1 7/8" wide and filed with "Cera-rod" 2" diameter backer rod from W.R. Meadows Co. or equivalent.

4.8 Seal 30' Wide Concrete Streets. The work shall consist of all traffic control, labor, material and equipment required to clean, seal, and squeegee all joints and cracks in the concrete pavement of 30' wide residential concrete streets, as specified in this document. Payment shall be made at the contract unit price per centerline linear foot of 30' wide residential concrete streets.

4.9 Traffic Control

4.9.1 Generally, one half of the street will be permitted to be worked on at one time. This results in two phases of work on each street. Additional phases will be required by City representatives in cases of intersecting streets, commercial entrances, sight distance issues, homeowner parking concerns, or any other issues determined by City representative.

4.9.2 The barricades used must conform to section 1063.3 of the specifications (slim line channelizers). The barricades must be kept in good working condition and must be monitored daily so the new concrete will remain protected until sufficiently cured. Minimum 3 inch wide yellow caution tape shall be used around the barricades to help keep bicycle riders from riding through the fresh concrete. On a typical section of concrete that measures 13-foot wide x 16-foot long there shall be at a minimum of seven (7) barricades per section. On longer sections of concrete there shall be barricade spacing of no wider than eight (8) feet. Minimum of three (3) barricades must be used on each end of a replaced section of concrete.

4.9.3 In addition, the Contractor is hereby advised that regular (no less than twice weekly) checks of the traffic control devices placed under this contract shall be conducted. The Contractor shall take immediate action to correct any devices found to be missing, out of place, or in need of repair or cleaning. Failure to correct any deficiency, whether found by the Contractor or as notified by the City, will result in the withholding of payment from the Contractor's invoice until such time the corrections are made and the devices are in place according to the original plan, or any approved modification thereof.

4.9.4 Deleted

4.9.5 Any road closures MUST be approved in advance, well designed and planned, and will include notification of schools, local businesses, emergency agencies, and any other required entities. Adequate detour routes shall be signed, and those signs maintained for the complete duration of the road closure.

4.10 Concrete Wash-Out. Proper methods of containment and disposal will be required. Any discharge to a storm inlet or ditch violates the City's illicit discharge ordinance (Chapter 422, Unified Development Ordinance). Inspection of containment methods will be monitored for compliance. A portable wash-out trailer or facility will be required on site for all wash clean-up.

4.11 Clean Up. Sweeping and clean up shall be performed daily, unless otherwise directed by the department representative. The contractor maybe required to use a street sweeper or self-powered broom to clean the required streets. All equipment and materials shall be removed if work is suspended for more than one week in a given subdivision.

4.12 Restoration. All finish work should be done as quickly as possible. Once the streets have re-opened to traffic, the backfill will be done within two (2) weeks. The cost to backfill curbs with topsoil and to seed & straw shall be included in the bid price for concrete replacement.

5. BASIS OF PAYMENT

5.1 Mobilization.

5.1.1 Mobilization shall be incidental with the cost of the contract. **No payment will be made.**

5.1.2 All the joint repairs will be within the streets listed for concrete slab replacement. No mobilization payment will be made.

5.2 Full Depth Saw Cutting. Saw cutting of concrete pavement will be paid at the bid price per linear foot. Saw cutting must be full depth to ensure protection of adjacent pavement to remain in place. Only saw cutting of existing concrete pavement prior to removal will be paid for under this item and only at the direction of the City Engineer or his representative. Saw cutting of construction joints in the newly placed concrete is incidental to the concrete placement and will not be paid for separately.

5.3 Concrete Replacement. Concrete replacement will be paid for as 6-inch thick. The replacement concrete will be replaced with EMPC mix. Payment will be at the appropriate unit price bid per square yard for both the thickness and the concrete mix required. **ALL** per square yard prices shall include cost for concrete removal, 4-inch subgrade removal, compacting the top 4-inch of remaining subgrade, 4-inch thick placement of 1-inch minus compacted rock base, installation of dowels, concrete replacement, traffic control placement and maintenance, providing and placing suitable backfill, seed and straw, sealing all joints, site cleanup, and restoration. The measurement for concrete removal and replacement will be made per square yard, regardless of the size and shape of marked concrete pavement.

5.4 Objectionable Material. The removal of objectionable material will be as directed by the City Engineer or his representative and will be made in writing. Measurement of material removed will begin at the depth below the existing pavement thickness and 4-inch subgrade removal as detailed elsewhere in these specifications. The size of base rock used for the replacement of unsuitable material (either 1-inch minus or 2-inch minus) shall be at the discretion of the City Engineer or his representative. No payment will be made for this item unless written direction has been provided and the volume of unsuitable

material has been field measured and documented by the City Engineer or his representative prior to the backfill with base rock.

5.6 Deleted

5.7 Concrete Curbs. Replacement of 3-inch rolled curb will be incidental to concrete pavement replacement and measured as part of the pavement replacement. All vertical curb replaced with a section of pavement will be poured integral with pavement.

5.8 Curb Inlet Sump. Four (4) square yards of concrete will be added to the total for each single curb inlet sump placed. Eight (8) square yards of concrete will be added to the total for each double curb inlet sump placed. All additional forming and concrete cost will be covered by these measurements.

5.9 Joint Repair, 4-foot to 8-foot wide. Joint repair will be paid for at the bid price per square yard. The majority of the replacement concrete will be replaced with EMPC mix (4000 psi at 28 days minimum). Payment will be at the appropriate square yard unit price for the concrete mix required. **ALL** per square yard prices include all cost for concrete removal, 4-inch subgrade removal, compacting the top 4-inch of remaining subgrade, placement of 4-inch of 1-inch minus compacted rock base, installation of dowels, 6” thick concrete replacement, traffic control placement and maintenance, providing and placing suitable backfill, seed and straw, sealing all joints, and site cleanup and restoration. The measurement for payment for joint repair will be made to the nearest 0.1 square yard.

6. PROJECT SUBMITTALS AND CLOSEOUT

6.1 Although not an all-inclusive list, the following submittals shall be required by the CONTRACTOR prior to the start of construction:

- Contract Agreement (CA-1 to CA-3, IB-1) Submitted: _____
- Certificate of Insurance (IB-4 to IB-5) Submitted: _____
- Affidavit of Work Authorization (IB-7) Submitted: _____
- List of Subcontractors (IB-1) Submitted: _____

6.2 The following documents are required from the CONTRACTOR to make Final Payment:

- Contractor's Certification Regarding Settlement of Claims (Prime) Submitted: _____
- Contractor's Final Lien Waiver (Prime) Submitted: _____
- All Subcontractors, shall supply final lien waivers for all material, labor and equipment. Submitted: _____
- Contractor's Final Pay Invoice (Prime) Submitted: _____
- Final Change Order (Prime) Submitted: _____
- Final inspection and approval by the CITY ENGINEER Submitted: _____

TYPICAL DRAWINGS

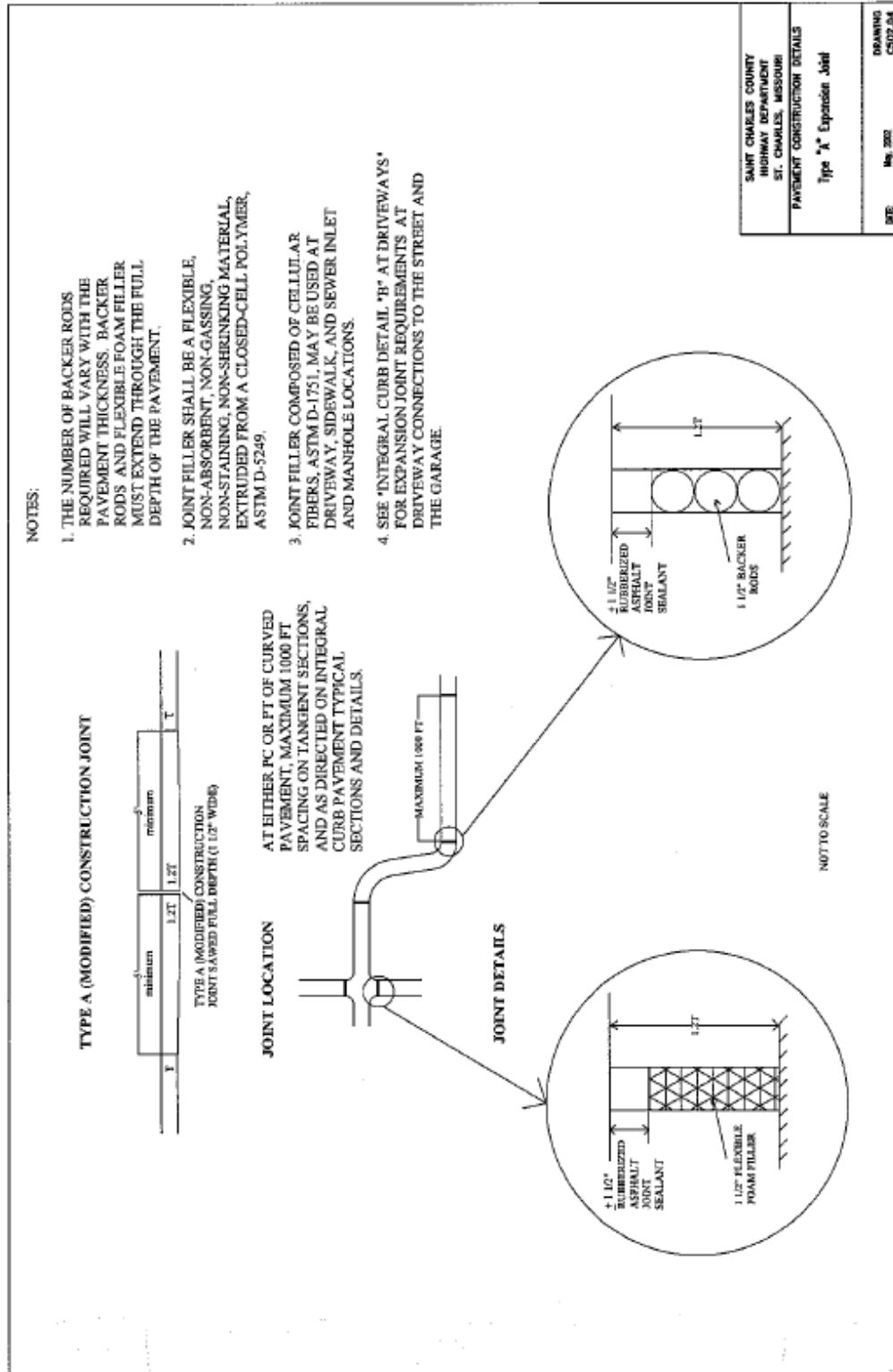

TYPICAL DRAWINGS

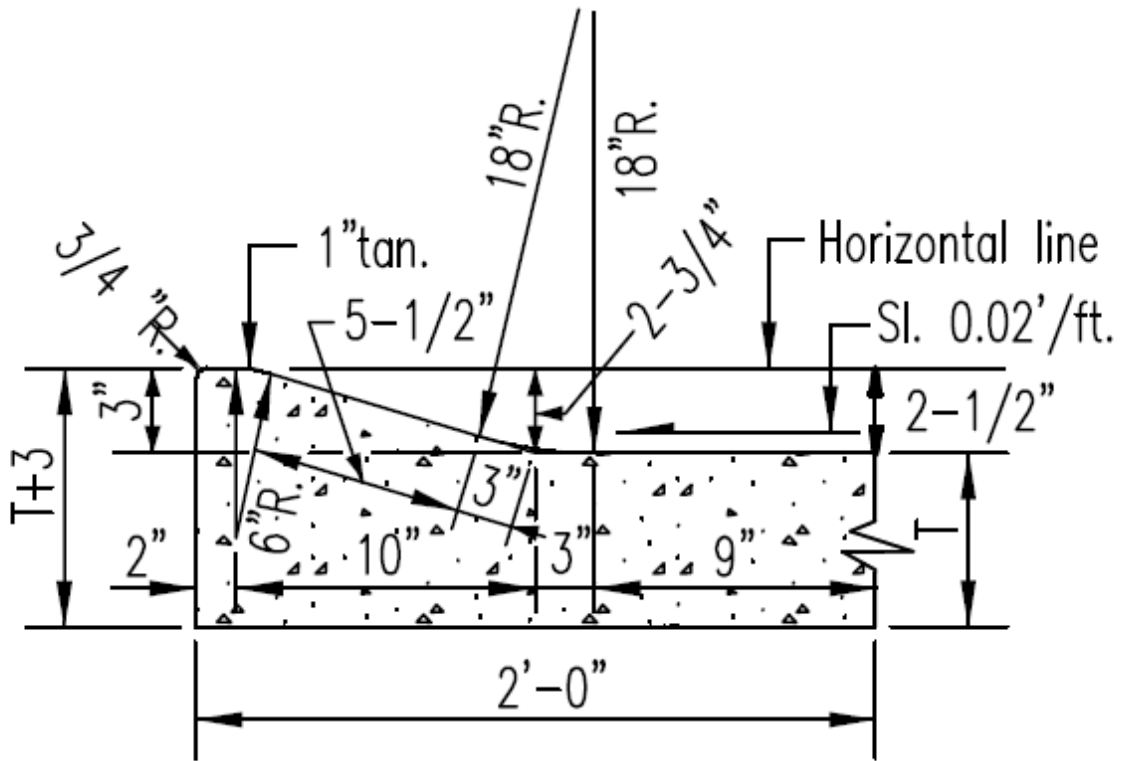

INTEGRAL ROLLED CURB

WORK ZONE TRAFFIC MANAGEMENT PLAN

1.0 Description. Work zone traffic management shall be in accordance with applicable portions of Division 100 and Division 600 of the Standard Specifications, and specifically as follows.

2.0 Traffic Management Schedule

2.1 Traffic management schedules shall be submitted to the engineer for review at or before the preconstruction meeting and prior to any revisions to the traffic management schedule. The traffic management schedule shall include the proposed traffic control measures, hours traffic control will be in place, and work hours.

2.2 The contractor shall notify the engineer prior to lane closures or shifting traffic onto detours. Any closures on MoDOT routes must be approved prior to closure by MoDOT. The notification of any lane closure is the responsibility of the contractor and the cancellation of lane closures is the responsibility of the City.

2.3 The engineer shall be notified as soon as practical of any postponement due to weather, material or other circumstances.

2.4 In order to ensure minimal traffic interference, the contractor shall schedule lane closures for the absolute minimum amount of time required to complete the work. Lanes shall not be closed until material is available for continuous construction and the contractor is prepared to diligently pursue the work until the closed lane is opened to traffic.

2.5 The contractor shall be responsible for maintaining the existing traffic flow through the job site during construction. If disruption of the traffic flow occurs and traffic is backed up in queues of 8 minute delays or longer, then the contractor shall review the construction operations which contributed directly to disruption of the traffic flow and make adjustments to the operations to prevent the queues from occurring again.

3.0 Work Hour Restrictions.

3.1 There are three major summer holiday periods: Memorial Day, Independence Day, and Labor Day. All lanes shall be scheduled to be open to traffic during these holiday periods, from 3:00 p.m. on the last working day preceding the holiday until 7:00 a.m. on the first working day subsequent to the holiday.

3.2 The contractor shall not perform any construction operation on the roadway, (including the hauling of material within the project limits), during restricted periods, holiday periods or other special events specified in the contract documents.

3.3 Working hours for evening, weekends and holidays will be determined by the engineer.

4.0 Detours and Lane Closures.

4.1 At least one lane of traffic shall be maintained at all times except for brief intervals of time required when the movement of the contractor's equipment will seriously hinder the safe movement of traffic. Periods during which the contractor will be allowed to halt traffic will be designated by the engineer.

4.2 Temporary daytime closures of one lane will be permitted provided adequate warning signs and flagmen to safely control traffic during construction are in place. Operations will be immediately

suspended should traffic restrictions be attempted on the existing roadway without the necessary flagmen being in place and properly equipped. No further payment will be made on the project until the Contractor has provided to the City sufficient proof that proper flagging procedures will be followed during any future operations requiring it.

4.2.1 On multi-lane pavements, lane closures will be permitted through the usage of flashing arrow panels, signage, and channelizers in lieu of flagman. A comprehensive lane closure plan, following the requirements spelled out in the Manual for Uniform Traffic Control Devices (MUTCD), must be submitted for approval prior to any lane closure. Arrow panels must be in good working order and all signs and channelizers must be clean and in generally good condition.

4.3 In addition, the Contractor is hereby advised that regular (no less than twice weekly) checks of the traffic control devices placed under this contract shall be conducted. The Contractor shall take immediate action to correct any devices found to be missing, out of place, or in need of repair or cleaning. Failure to correct any deficiency, whether found by the Contractor or as notified by the City, will result in the withholding of payment from the Contractor's invoice until such time the corrections are made and the devices are in place according to the original plan, or any approved modification thereof.

5.0 Basis of Payment. No direct payment will be made to the contractor to recover the cost of equipment, labor, materials or time required to fulfill the above provisions, in the work zone traffic management plan.

**CONTRACT AGREEMENT
CONCRETE REMOVAL AND REPLACEMENT**

This Contract Agreement (this "Agreement") is made and entered into as of the ____ day of _____, 2022, by and between _____ (hereinafter called the "Contractor"), and the City of Cottleville, a Missouri municipal corporation (hereinafter called the "City"). *All capitalized terms used and not defined herein shall have the meanings ascribed to them in the Contract Documents (as hereinafter defined).*

RECITALS

A. In response to an Invitation for Formal Bids from the City for Concrete Street Slabs Removal and Replacement (the "Project"), the Contractor has submitted a certain bid to perform the work (as described in Article 1) (the "Bid").

B. After due consideration, the City has accepted the Bid of the Contractor and the parties hereto desire to enter into this Agreement whereby the Contractor shall undertake the performance of the Services in accordance with the Contract Documents (as defined in Article 6) and the City shall pay the Contractor as hereinafter specified.

NOW, THEREFORE, in consideration of the foregoing recitals, which are incorporated herein by reference, the mutual promises hereinafter set forth, and other good and valuable consideration, the receipt and sufficiency of which are hereby acknowledged, the City and the Contractor hereby agree as follows:

ARTICLE 1. SCOPE OF THE WORK:

The Contractor shall furnish all of the material, tools, equipment, labor and incidentals necessary to perform, and shall perform in accordance with the specifications and terms set forth in the documents identified in the Contract Documents (as defined in Article 6 below), all of the work described in the Contract Documents. Except as expressly specified herein, Contractor hereby agrees to provide all of the supervision, labor, technical services, facilities, materials, tools, equipment, and apparatus necessary to perform the work, and to do all the things necessary for the proper completion of the work. All work shall be performed in conformance with all applicable ordinances of the City, laws of the State of Missouri, federal laws, and all rules and regulations thereunder.

ARTICLE 2. TIME OF COMPLETION:

The Contractor shall commence work following a written notice-to-proceed from the City to begin work and shall fully complete all work under this contract prior to September 30, 2022. With the rate of progress and the time of completion being essential conditions of this contract, liquidation damages will be charged for failure to complete within the allotted time at the rate of three hundred (\$300.00) dollars per day for each calendar day until the job is completed, accepted, and approved by the City.

ARTICLE 3. PAY QUANTITIES AND UNIT PRICES:

The City shall pay the contractor for all work done based on final computations for all work acceptably completed according to this Agreement, at the unit price shown in the Bid for the quantity actually installed. The Contractor shall submit to the City all invoices complete with necessary supporting

documentation and lien waivers. The City shall make payment within 30 days of receipt of an invoice after satisfactory performance of the work. Invoices shall be submitted no more than once per month except for the final payment. Payment Terms: net 30 days. Remit Address: City Clerk, City of Cottleville, 5490 Fifth Street, Cottleville, MO 63304. A 5% retainage will be held from all invoices submitted to the City for payment until the final lien waivers and other close out paperwork are furnished to the City. The City is exempt from federal excise tax and Missouri sales tax and the Contractor shall not charge the same to the City.

ARTICLE 4. GUARANTEE:

The Contractor hereby expressly guarantees the aforesaid work as to workmanship in connection therewith for a term of one year, commencing on the date of acceptance of the work, and binds itself, its successors and assigns, to make all repairs or replacements which may become necessary within the one year time period due to nonconformity with the Contract Documents. Whenever notified by the City that said replacements are required, the Contractor shall immediately make the same as directed and at its own expense. If the Contractor does not proceed with such replacements within five days after receipt of written notice of such replacement, then the City shall have the power to cause the same to be made and to charge the cost thereof to the Contractor and its sureties. Nothing in this Article is intended to be a guarantee of the maintenance of the improvements constructed by the Contractor.

ARTICLE 5. FINAL PAYMENT AND ACCEPTANCE:

When all work provided for under this Agreement has been completed in conformance with the specifications and requirements of this Agreement, and accepted without regard to the provisions of guarantee as provided under the terms of this Agreement, final cost estimate shall be prepared and submitted to the City Engineer within fifteen (15) days after the date of acceptance of the work as a statement of the amount due the contractor along with the final lien waivers. This estimate shall be based on line items provided in the Agreement, including any charges for extra work ordered and properly chargeable and/or deductible under this Agreement.

ARTICLE 6. THE CONTRACT DOCUMENTS:

The Invitation for Bids, Information for Bidders, Wage Rates, Bid, and Specifications, and all Exhibits and duly-issued modifications thereto, together with this Agreement form the Contract Documents. The St. Charles County Standard Specifications for Arterial Highway Construction, 2006 is a part of this Agreement as fully as if hereto attached. Whenever any provision of the Contract Documents conflict, the provision most advantageous to the City shall govern.

ARTICLE 7. RATES OF PAY; BONDING:

For any project performed pursuant to this Agreement, the cost of which is in excess of \$75,000.00, the Contractor shall take all such actions as are necessary to ensure that not less than the prevailing hourly rate of wages shall be paid to all workmen performing such work under this Agreement. Pursuant to Section 290.250, RSMo., Contractor shall forfeit as a penalty to the City one hundred dollars for each workman employed, for each calendar day, or portion thereof, such workman is paid less than the said stipulated rates for any applicable work done under said Agreement, by Contractor or by any subcontractor under Contractor.

For any project performed pursuant to this Agreement, the cost of which is in excess of \$50,000.00, the Contractor shall furnish to the City a payment bond in the amount equal to the estimated cost of such

project, and such bond, among other conditions, shall be conditioned for the payment of any and all materials, incorporated, consumed or used in connection with the construction of such work, and all insurance premiums, both for compensation, and for all other kinds of insurance, said work, and for all labor performed in such work whether by subcontractor or otherwise, under the terms of this Agreement.

ARTICLE 8. SAFETY PROGRAM TRAINING REQUIREMENT:

Pursuant to Section 292.675 RSMo., Contractor shall require all on-site employees to complete the ten-hour training program as required under Subsection 292.675.2, RSMo. This program shall be provided by Contractor and shall be a ten-hour Occupational Safety and Health Administration (“OSHA”) construction safety program for Contractor’s on-site employees which includes a course in construction safety and health approved by OSHA or a similar program approved by the Missouri Department of Labor and Industrial Relations (“MoDOLIR”) which is at least as stringent as an approved OSHA program. All employees are required to complete the program within sixty (60) days of beginning work under this Agreement. Contractor shall further require all subcontractors under Contractor to provide the ten-hour training program required under Subsection 292.675.2, RSMo., to such subcontractors’ on-site employees. On-site employees who have previously completed such ten-hour training program must hold documentation of prior completion of the program.

Pursuant to Section 292.675, RSMo, Contractor shall forfeit to City as a penalty two thousand five hundred dollars (\$2,500.00), plus one hundred dollars (\$100.00) for each on-site employee employed by Contractor or its subcontractors, for each calendar day, or portion thereof, such on-site employee is employed without the required construction safety training. MoDOLIR shall investigate any claim of violation of Section 292.675, RSMo. Upon City’s receipt of notification from MoDOLIR of violations of 292.675, RSMo., by Contractor and a determination by MoDOLIR that penalties shall be assessed for such violations, the City shall withhold and retain from the Agreement all sums and amounts due and owing to the City as a result of any violation of Section 292.675, RSMo. All words in this Article shall have the meaning as provided in Section 292.675.1, RSMo.

ARTICLE 9. AUDIT CLAUSE FOR CONTRACTS: (Examination of Records)

Examination of Records

The Contractor's records shall include, but not be limited to, accounting records (hard copy, as well as computer readable data), written policies and procedures, subcontractor files, indirect cost records, overhead allocation records, correspondence, instructions, drawings, receipts, vouchers, memoranda, and any other data relating to this Agreement and shall be open to inspection and subject to audit and/or reproduction by the City Auditor, or a duly authorized representative from the City, at the City's expense. The Contractor shall preserve all such records for a period of three years, unless permission to destroy them is granted by the City, or for such longer period as may be required by law, after the final payment. Since the Contractor is not subject to the Missouri Sunshine Law (Chapter 610, RSMo), information regarding the Contractor's operations obtained during audits will be kept confidential.

The Contractor shall require all subcontractors under this Agreement to comply with the provisions of this Article by including the requirements listed above in written contracts with the subcontractors.

ARTICLE 10. INDEPENDENT CONTRACTOR:

The Contractor shall be and operate as an independent Contractor in the performance of the work. The Contractor shall have complete charge of the personnel engaged in the performance of the work, and all persons employed by the Contractor shall be employees of said Contractor and not employees of the City in any respect.

ARTICLE 11. INDEMNIFICATION:

To the fullest extent permitted by law, the Contractor agrees to defend with counsel approved by the City, indemnify and hold harmless the City, its officers, engineers, representatives, agents and employees from and against any and all liabilities, damages, losses, claims or suits, including costs and attorneys' fees, for or on account of any kind of injury to person, bodily or otherwise, death, damage to or destruction of property, money damages, trespass, or any other circumstances, sustained by the City or others, arising from the Contractor's breach of the Agreement or out of services or products provided by the Contractor or its subcontractors under the terms of this Agreement. The Contractor shall not be liable for any loss or damage attributable solely to the negligence of the City. To the extent required to enforce this provision, the Contractor agrees that this indemnification requires the Contractor to obtain insurance in amounts specified in the Contract Documents and that the Contractor has had the opportunity to recover the costs of such insurance in the compensation set forth in this Agreement.

In any and all claims against the City, its officers, engineers, representatives, agents and employees by any employee of the Contractor, any subcontractor, anyone directly or indirectly employed by any one of them, or anyone for whose acts any of them may be liable, this indemnification obligation shall not be limited in any way by any limitation on the amount or type of damages, compensation or benefits payable by or for the Contractor or any Subcontractor under workmen's compensation acts, disability benefit acts or other employee benefit acts.

ARTICLE 12. OTHER REPRESENTATIONS, WARRANTIES AND OTHER COVENANTS BY THE CONTRACTOR:

The Contractor represents and warrants that the Contractor has been engaged in such work as is required under the Contract Documents and that the Contractor has sufficient expertise, knowledge, information and data, and engages sufficient personnel, to perform the Contractor's obligations under this Agreement. The Contractor further represents and warrants that the Contractor is an equal opportunity employer. The Contractor agrees that the Contractor shall not use in any form or medium the name of the City for any advertising unless the Contractor receives the prior written consent of the City.

ARTICLE 13. AMENDMENT; WAIVER:

No amendment, modification or waiver of any provision of this Agreement shall be effective unless in writing signed by an authorized representative of the party against whom such provision as amended or modified or such waiver is sought to be enforced. Failure to insist upon strict compliance with any of the terms or conditions of the Agreement shall not be deemed a waiver of such term or condition.

ARTICLE 14. ATTORNEY FEES' AND COSTS:

The Contractor shall reimburse to the City any costs and attorneys' fees that the City may reasonably incur in pursuit of any remedies at law or equity or enforcement of any rights established in this Agreement, which may result from the Contractor's breach of the Agreement, the Contractor's failure to perform any obligation or requirement contained herein, or the City's enforcement of this Agreement.

ARTICLE 15. TERMINATION:

The City shall have the right to terminate this Agreement at any time for any reason by giving the Contractor written notice to such effect. The City shall pay to the Contractor in full satisfaction and discharge of all amounts owing to the Contractor under this Agreement an amount equal to the cost of all work performed by the Contractor up to such termination date, less all amounts previously paid to

the Contractor for such work. The Contractor shall submit to the City its statement for the aforesaid amount, in such reasonable detail as the City shall request, within thirty (30) days after such date of termination. The City shall not be liable to the Contractor for any damages on account of such termination for loss of anticipated future profits with respect to the remainder of the work under this Agreement.

ARTICLE 16. COMPLIANCE WITH STATE IMMIGRATION STATUTES:

As a condition for the award of this Agreement, the Contractor shall, by sworn affidavit and provision of documentation, affirm its enrollment and participation in a federal work authorization program with respect to the employees working in connection with the Services. The Contractor shall also sign an Affidavit of Participation in Federal Work Authorization Program, in substantially the form included in the Invitation for Formal Bids, affirming that it does not knowingly employ any person who is an unauthorized alien in connection with the work. The Contractor shall not be required to provide these affidavits to the City if such affidavits have been previously provided to the City within the past year. All words in this Article shall have the definitions as provided in Section 285.525 RSMo. Contractor therefore covenants that it is not knowingly in violation of subsection 1 of Section 285.530, RSMo, and that it will not knowingly employ, hire for employment, or continue to employ any unauthorized aliens to perform work on the Project, and that its employees are lawfully eligible to work in the United States.

ARTICLE 17. SUBCONTRACTS:

The Contractor shall not subcontract any of the work to be performed by it hereunder without the express written consent of the City, except as provided herein. If the Contractor utilizes a subcontractor, the Contractor shall ensure that any agreement between Contractor and such subcontractor complies with all requirements imposed for such agreement by federal, state, and local law. In addition, this Agreement shall not be assigned by the Contractor.

If the Contractor submits invoices to the City which include payments to be made on account of work performed by a subcontractor, such payments shall be conditioned upon submission by the Contractor of waivers of liens, or such other documents satisfactory to the City to protect the City's title to land, buildings, or improvements or to otherwise protect the City's interest. By submitting an invoice to the City, the Contractor warrants and guarantees that title to all land, buildings or improvements which may be subject to a lien under 429.015, RSMo., upon the receipt of such payment by the Contractor, will not be subject to a lien under 429.015, RSMo.

ARTICLE 18. OTHER CONTRACTORS:

The City reserves the right to employ other Contractors in connection with the work to be performed under this Agreement.

ARTICLE 19. GOVERNING/CHOICE OF LAW; JURISDICTION:

This Agreement shall be governed by, construed and interpreted in accordance with the internal laws of the State of Missouri, without regard to its principles of conflict of laws, and shall be deemed to be executed and performed in the County of St. Charles, Missouri. Any legal action arising out of, or relating to this Agreement, shall be governed by the laws of the State of Missouri, and the parties agree to the exclusive jurisdiction and venue over them by a court of competent jurisdiction located in the County of St. Charles, Missouri, or the U.S. District Court for the Eastern District of Missouri.

ARTICLE 20. HEADINGS:

The headings contained herein are for convenience only and are not intended to limit, vary, define or expand the content thereof.

ARTICLE 21. REPRESENTATIONS:

Contractor agrees that it has not relied on any representations or warranties of the City, oral or written, other than expressly identified in this Agreement. The parties agree this Agreement represents the entire agreement between the parties.

ARTICLE 22. SEVERABILITY:

The invalidity or unenforceability of any portion or provision of this Agreement shall not affect the validity or enforceability of any other portion or provision of this Agreement, which shall remain in full force and effect to the maximum extent permitted by law.

ARTICLE 23. COUNTERPARTS:

This Agreement may be executed in one or more counterparts each of which shall be deemed an original and all of which shall constitute one and the same agreement.

IN WITNESS WHEREOF, the parties have entered into this Agreement on the date last written below:

Executed by the City this _____ day of _____, 20__.

Executed by the Contractor this _____ day of _____, 20__.

CONTRACTOR: _____

CITY OF COTTLEVILLE, MO

BY _____

Rich Francis, City Administrator

TITLE _____

ATTEST _____

ATTEST _____
Amy Lewis, City Clerk

PERFORMANCE BOND

KNOW ALL MEN BY THESE PRESENTS, that we, the Undersigned _____

_____ of _____

(firm
*a (corporation, duly authorized by law to do business as a construction
(partnership

contractor in the State of _____, and _____

_____ of _____

(hereinafter called the "Surety"), a corporation duly authorized to do a Surety business under the laws of the State of Missouri, are held and firmly bound unto the St. Charles County, (hereinafter called the "County"), in the penal sum of _____ Dollars (\$_____).

lawful money of the United States, for the payment of which to be made unto said City, we bind ourselves, our heirs, executors administrators, successors and assigns, jointly and severally, firmly by these presents as follows:

The conditions of this obligation are such that, whereas on the _____ day of _____ 20____, the said Principal entered into a written Agreement, which Agreement is hereby made a part hereof, with the said City for the construction of :

NOW THEREFORE, if the said Principal shall faithfully and properly perform the foregoing Contract according to all the terms thereof, and shall, as soon as the work contemplated by said contract is completed, pay to the proper parties all amounts due for all labor and material required by this contract in the construction of such work, and all insurance premiums for both compensation and all other kinds of insurance on said work, and for all labor performed in such work whether by subcontractor or otherwise, then this obligation shall be void. Otherwise it shall remain in full force and effect, and may be called on for the use and benefit by any person furnishing material or performing labor, either as an individual or as a subcontractor, for any contractor in the name of said City.

Every Surety on this bond shall be deemed and held, any contractor on the contrary notwithstanding, to consent without notice.

- a) To the extension of time to the contractor in which to perform the contract
- b) To changes in the plans, specifications, amount of work or contract.
- c) That no provisions of this bond or of any other contract shall be valid which limits to less than one (1) year from the date of final acceptance of the work the right to sue on this bond for defects in workmanship or material not discovered or known to the City at the time such work was accepted.

IN TESTIMONY WHEREOF, the Parties hereunto have caused the execution hereof in _____ original counterparts as of the _____ day of _____, 20_____.

*Line out the inapplicable designation.

Principal

(SEAL)

ATTEST:

BY _____

PAYMENT AND MATERIALS BOND

KNOW ALL MEN BY THESE PRESENT, that we, _____
Principal and Address
_____, as Principal, and _____,
Surety and Address

as Surety, are held and firmly bond unto the County of St. Charles, Missouri, hereinafter called Obligee, in the amount of \$ _____, for the payment of which we jointly and severally bind ourselves, our heirs, executors, administrators, successors, trustees, and assigns firmly by these presents.

WHEREAS, the Principal has entered into a contract with Obligee for _____
describe briefly
_____ ; and

WHEREAS, the Obligee requires the Principal enter into a surety bond satisfying the terms of Section 107.170 R.S. Mo.

NOW, THEREFORE, THE CONDITION OF THIS OBLIGATION is such, that if the Principal shall pay, or cause to be paid in full, the claims of all persons performing labor upon, or furnishing materials to be used in, or furnishing appliances, equipment, or power contributing to such work under said contract, then this obligation shall be void; otherwise to remain in full force and effect. The total amount of surety's liability under this bond shall in no event exceed the amount hereof, and in no event shall the undertaking hereby be construed to impose liability on the surety beyond that required by the terms of Section 107.170 R.S. Mo.

Signed and sealed this _____ day of _____, 20_____.

BY: _____
PRINCIPAL

BY: _____
SURETY